

JVC



English

Français

SPEAKER SYSTEM
ENCEINTE ACOUSTIQUE

SX-WD5



INSTRUCTIONS

MANUEL D'INSTRUCTIONS

For Customer Use:

Enter below the Model No. and Serial No. which are located either on the rear, bottom or side of the cabinet. Retain this information for future reference.

Model No. _____

Serial No. _____

LVT1236-004A

[J]

Warnings, Cautions and Others

■ Precautions for installation

- Do not install the speakers on an uneven surface or in a place subject to vibration; otherwise, they may fall over, causing damage or injury.
 - Take the occurrence of earthquakes or other physical shocks into consideration when selecting the installation place, and secure the speakers thoroughly.
- To prevent deformation or discoloration of the cabinet, do not install the speakers where they are exposed to direct sunlight or high humidity, and avoid installation near air conditioning outlets.
- Speaker vibrations may cause howling. Place the speakers as far away from the player as possible.
- The speakers are magnetically shielded to avoid color distortions on TVs. However, if not installed properly, it may cause color distortions. So, pay attention to the following when installing the speakers.
 - When placing the speakers near a TV set, turn off the TV's main power switch or unplug it before installing the speakers.
Then wait at least 30 minutes before turning on the TV's main power switch again. Some TVs may still be affected even though you have followed the above. If this happens, move the speakers further away from the TV.
- Tuner reception may become noisy or hissing if a speaker is installed near the tuner. In this case, leave more distance between the tuner and the speakers or use an outdoor antenna for better tuner reception without interference from the speakers.

■ Precautions for daily use

- **To maintain the appearance of the speakers**
 - Wipe with a dry, soft cloth if the cabinet should become dirty.
If very dirty, wipe with a cloth applied a small amount of water or neutral detergent, then wipe with a dry cloth.
 - Do not use chemicals such as benzine and thinner for cleaning the cabinet; otherwise, the speakers may deteriorate or its paint may come off.
- **To improve the sound field**
 - It is recommended to leave a space of more than 50 cm between the speakers and the wall.
 - If the speakers are facing a solid wall or glass door, etc., it is recommended to furnish the wall with materials that absorb sounds, for example by hanging up thick curtains, to prevent reflections and standing waves.
- **To use the speakers without any trouble**
 - Do not reproduce sounds at so high a volume that they are distorted; otherwise, the speakers may be damaged by internal heat buildup.
 - When moving the speakers, do not pull the speaker cords; otherwise, the speakers may fall over, causing damage or injury.

Connection

■ Precautions

Before connecting:

- Make sure to match the polarity (\oplus and \ominus) when connecting the speaker cords.
- Turn off the power to the amplifier before connecting the speaker system; otherwise, the speakers may be damaged.
- The impedance of the speaker is 6Ω .
If this does not match with the speaker impedance range indicated on the amplifier, you cannot connect this system to the amplifier.
- The maximum power handling capacity of the SX-WD5 is 100 W. Excessive input will result in abnormal noise and possible damage.

Daily operations and maintenance:

- Be sure to turn down the volume level on the amplifier to prevent unwanted noise before performing following operations:
 - Turning on or off other components
 - Operating the amplifier
 - Tuning FM stations
 - Fast-forwarding a tape
 - Continuously reproducing high frequency oscillation or high pitch electronic sounds
 - Connecting or disconnecting a microphone
- When using a microphone, do not aim it at the speakers or use it near the speakers; otherwise, the howling which occurs may damage the speakers.
- Before replacing the cartridge, always turn off the power both to the amplifier and to the turntable; otherwise, the clicking noise may damage the speakers.

■ Connecting the speaker system to the amplifier

- Twist and remove the insulation at the end of each speaker cord before connecting.

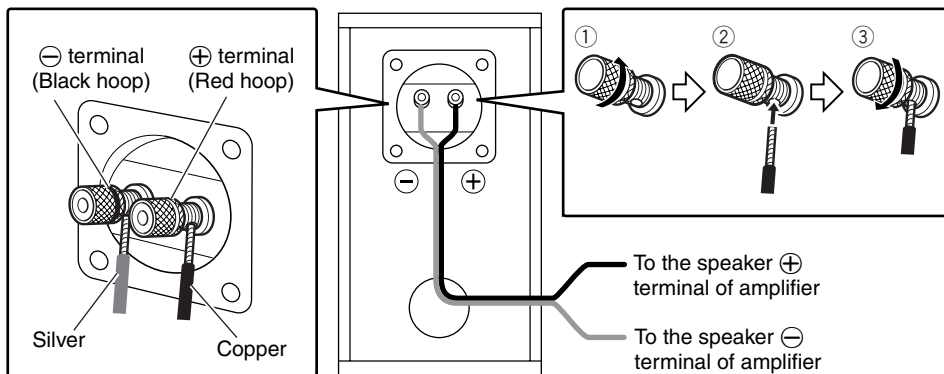

About Speaker Grille

The speaker grille is removable as illustrated below:

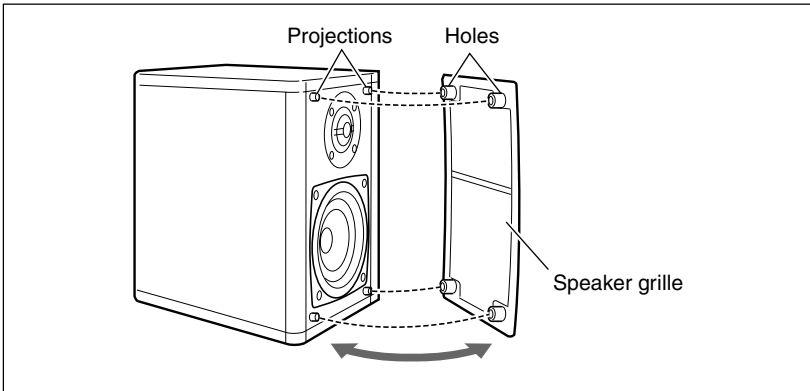

To remove the speaker grille, insert your fingers at the top of the speaker grille, then pull towards you. Repeat the procedure at the bottom of the speaker grille.

To attach the speaker grille, put the projections of the speaker into the holes of the speaker grille.

- Do not push the speaker grille strongly.

Specifications

Type:	2-way bass-reflex type Magnetically-shielded type
Speakers	
Mid and low range:	10.5 cm (4 ³ / ₁₆ in.) wooden cone
Tweeter:	2.0 cm (¹³ / ₁₆ in.) wooden dome
Power handling capacity:	100 W
Impedance:	6 Ω
Crossover frequency:	3 500 Hz
Frequency range:	55 Hz to 50 000 Hz
Sound pressure level:	82 dB/W•m
Dimensions (W x H x D):	143 mm x 257 mm x 243 mm (5 ¹¹ / ₁₆ in. x 10 ¹ / ₈ in. x 9 ⁵ / ₈ in.)
Mass:	3.5 kg (7.81 lbs)
Supplied accessory:	Speaker cord (3 m) (1)

Design and specifications subject to change without notice.

Avertissements, précautions et autres

■ Précautions pour l'installation

- N'installez pas les enceintes sur une surface accidentée ou dans un endroit sujet aux vibrations; sinon, elles risquent de tomber causant des dommages ou des blessures.
 - Lors de la sélection de l'emplacement d'installation des enceintes prenez aussi en considération les tremblements de terre ou d'autres chocs physiques, et fixez les en conséquence.
- Pour éviter la déformation ou la décoloration du boîtier, n'installez pas les enceintes dans un endroit exposé directement au soleil ou à une forte humidité, et évitez de les installer près d'une sortie de climatiseur.
- Les vibrations des enceintes peuvent causer des hurlements. Placez-les aussi loin que possible du lecteur.
- Les enceintes sont blindées magnétiquement pour éviter toute distorsion des couleurs sur les téléviseurs. Cependant, si elles ne sont pas installées correctement, elles peuvent causer des distorsions des couleurs. Faites attention aux points suivants lors de l'installation des enceintes.
 - Lors de l'installation des enceintes près d'un téléviseur, mettez le téléviseur hors tension ou débranchez-le avant d'installer les enceintes.
Attendez ensuite 30 minutes avant de remettre le téléviseur sous tension.
Certains téléviseurs peuvent quand même être affectés même si vous avez suivi les points ci-dessus. Si cela se produit, éloigné les enceintes du téléviseur.
- La réception du tuner peut devenir parasitée ou des sifflements peuvent se produire si une enceinte est installée près du tuner. Dans ce cas, éloigné un peu plus le tuner de l'enceinte ou utilisez une antenne extérieure pour obtenir une meilleure réception du tuner sans interférence des enceintes.

■ Précautions pour une utilisation quotidienne

- **Pour conserver l'apparence des enceintes**
 - Frottez le boîtier avec un chiffon sec et doux s'il est sale.
S'il est très sale, frottez-le avec un chiffon imprégné d'une petite quantité de détergent neutre, puis essuyez avec un chiffon sec.
 - N'utilisez pas de produit chimique tel que de la benzine et un diluant pour nettoyer le boîtier. Cela pourrait endommager les enceintes ou faire partir leur peinture.
- **Amélioration du champ acoustique**
 - Il est recommandé de laisser un espace d'au moins 50 cm entre les enceintes et le mur.
 - Si les enceintes font face à un mur solide ou à une porte vitrée, etc., il est recommandé de recouvrir le mur de matériaux absorbant le son, comme par exemple en suspendant des rideaux épais, afin d'éviter les réflexions et les ondes stationnaires.
- **Pour utiliser les enceintes sans aucun problème**
 - Ne reproduisez pas des sons à un volume si élevé qu'ils sont déformés; sinon, les enceintes peuvent être endommagées par un échauffement interne.
 - Lors du déplacement des enceintes, ne tirez pas sur les cordons d'enceinte; sinon, les enceintes risquent de tomber et de causer des dommages ou des blessures.

Connexions

■ Précautions

Avant la connexion:

- Assurez-vous de respecter les polarités (\oplus et \ominus) lors de la connexion des cordons d'enceinte.
- Mettez l'amplificateur hors tension avant de connecter le système d'enceinte; sinon les enceintes risquent d'être endommagées.
- L'impédance de l'enceinte est de 6Ω .

Si cela ne correspond pas avec la plage d'impédance d'enceinte indiquée sur l'amplificateur, vous ne pouvez pas connecter ce système à l'amplificateur.

- La capacité de puissance soutenue maximale du SX-WD5 est de 100 W. Un niveau d'entrée excessif peut entraîner des bruits anormaux et d'éventuels dommages.

Utilisation quotidienne et entretien:

- Assurez-vous de réduire le niveau de volume sur l'amplificateur pour éviter que du bruit indésirable ne soit produit pendant les opérations suivantes:
 - Mise sous ou hors tension des autres appareils
 - Utilisation de l'amplificateur
 - Accord des stations FM
 - Avance rapide d'une bande
 - Reproduction continue d'oscillation à haute fréquence ou de sons électroniques très hauts
 - Lors de la connexion ou déconnexion d'un microphone
- Lors de l'utilisation d'un microphone, ne le dirigez pas vers les enceintes ni ne l'utilisez près des enceintes; sinon, un hurlement risquerait de se produire et d'endommager les enceintes.
- Avant de remplacer la cellule, coupez toujours le son sur l'amplificateur et sur le tourne-disque; sinon, le bruit de craquement peut endommager les enceintes.

■ Connexion du système d'enceinte à l'amplificateur

- Torsadez et retirez l'isolant à l'extrémité de chaque cordon d'enceinte avant la connexion.

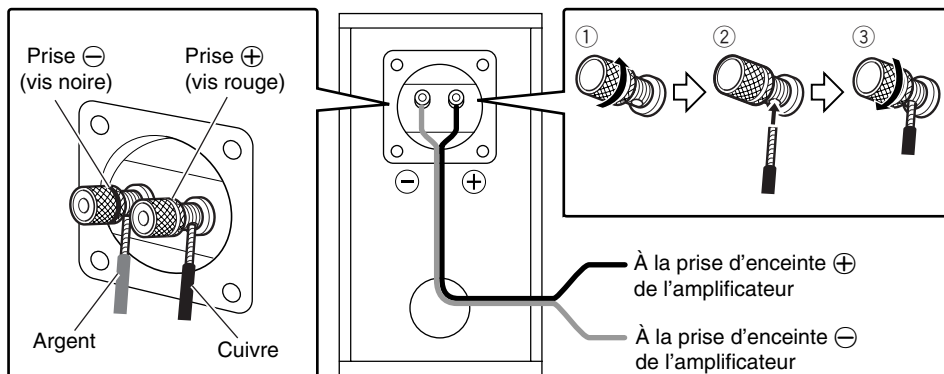
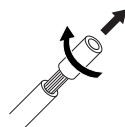

À propos de la grille de l'enceinte

La grille de l'enceinte peut être retirée comme montré sur l'illustration.

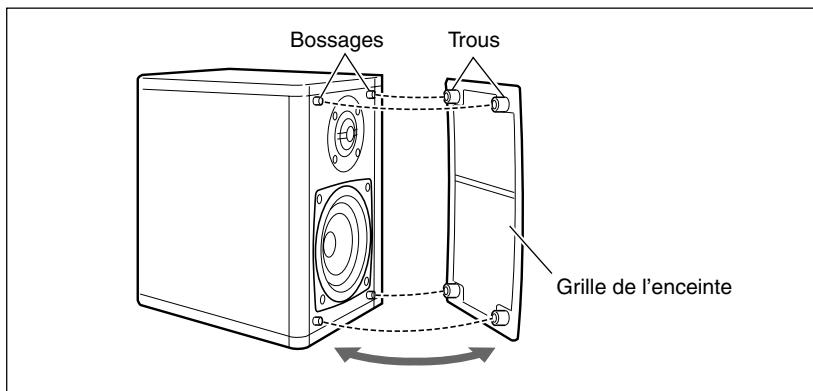

Pour retirer la grille de l'enceinte, insérez vos doigts en haut de la grille, puis tirez vers vous. Répétez cette procédure en bas de la grille de l'enceinte.

Pour attacher la grille de l'enceinte, insérez les bossages de l'enceinte dans les trous de la grille.

- Ne poussez pas trop fort sur la grille de l'enceinte.

Spécifications

Type:	2 voies, à évent accordé, blindé magnétiquement
Haut-parleurs	
Plage des médiums et des graves:	Cône en bois de 10,5 cm ($4 \frac{13}{16}$ pouces)
Haut-parleur d'aigus:	Dôme en bois de 2,0 cm ($1 \frac{3}{16}$ pouces)
Capacité de puissance soutenue:	100 W
Impédance:	6 Ω
Fréquence de transition:	3 500 Hz
Plage de fréquences:	55 Hz à 50 000 Hz
Niveau de pression acoustique:	82 dB/W•m
Dimensions (L x H x P):	143 mm x 257 mm x 243 mm ($5 \frac{11}{16}$ pouces x $10 \frac{1}{8}$ pouces x $9 \frac{5}{8}$ pouces)
Masse:	3,5 kg (7.81 livres)
Accessoire fourni:	Cordon d'enceinte (3m) (1)

La conception et les spécifications sont sujettes à changement sans notification.



LIMITED WARRANTY

AUDIO-1

JVC COMPANY OF AMERICA (JVC) warrants this product and all parts thereof, except as set forth below ONLY TO THE ORIGINAL RETAIL PURCHASER to be FREE FROM DEFECTIVE MATERIALS AND WORKMANSHIP from the date of original purchase for the period as shown below. (iThe Warranty Period)

PARTS	1 YR	LABOR	1 YR
-------	-------------	-------	-------------

THIS LIMITED WARRANTY IS VALID ONLY IN THE FIFTY (50) UNITED STATES, THE DISTRICT OF COLUMBIA AND IN THE COMMONWEALTH OF PUERTO RICO.

WHAT WE WILL DO:

If this product is found to be defective within the warranty period, JVC will repair or replace defective parts with new or rebuilt equivalents at no charge to the original owner. Such repair and replacement services shall be rendered by JVC during normal business hours at JVC authorized service centers. Parts used for replacement are warranted only for the remainder of the Warranty Period. All products may be brought to a JVC authorized service center on a carry-in basis. Color television with a screen size of 27" and or greater qualify for in-home service. In such cases, a technician will come to your home and either repair the TV there or remove and return it if it cannot be repaired in your home.

WHAT YOU MUST DO FOR WARRANTY SERVICE:

Please do not return your product to the retailer

Instead, return your product to a JVC authorized service center nearest you. If shipping the product to the service center, please be sure to package it carefully, preferably in the original packaging, and include a brief description of the problem(s). Please call 1-800-252-5722 to locate the nearest JVC authorized service center. Service locations can also be obtained from our website <http://www.jvc.com>. If your product qualifies for in-home service, the service representative will require clear access to the product.

If you have any questions concerning your Product, please contact our Customer Relations Department at 800-252-5722.

WHAT IS NOT COVERED:

This limited warranty provided by JVC does not cover:

1. Products which have been subject to abuse, accident, alteration, modification, tampering, negligence, misuse, faulty installation, lack of reasonable care, or if repaired or serviced by anyone other than a service facility authorized by JVC to render such service, or if affixed to any attachment not provided with the products, or if the model or serial number has been altered, tampered with, defaced or removed;
2. Initial installation and installation and removal from cabinets or mounting systems;
3. Operational adjustments covered in the Owner's Manual, normal maintenance, video and audio head cleaning;
4. Damage that occurs in shipment, due to act of God, and cosmetic damage;
5. Signal reception problems and failures due to line power surge;
6. Video Pick-up Tubes/CCD Image Sensors are covered for 90 days from the date of purchase;
7. Accessories;
8. Batteries (except that Rechargeable Batteries are covered for 90 days from the date of purchase);
- 9.

There are no express warranties except as listed above.

THE DURATION OF ANY IMPLIED WARRANTIES, INCLUDING THE IMPLIED WARRANTY OF MERCHANTABILITY, IS LIMITED TO THE DURATION OF THE EXPRESS WARRANTY HEREIN.

JVC SHALL NOT BE LIABLE FOR THE LOSS OF USE OF THE PRODUCT, INCONVENIENCE, OR ANY OTHER DAMAGES, WHETHER DIRECT, INCIDENTAL OR CONSEQUENTIAL (INCLUDING, WITHOUT LIMITATION, DAMAGE TO TAPES, RECORDS OR DISCS) RESULTING FROM THE USE OF THIS PRODUCT, OR ARISING OUT OF ANY BREACH OF THIS WARRANTY. ALL EXPRESS AND IMPLIED WARRANTIES, INCLUDING THE WARRANTIES OF MERCHANTABILITY AND FITNESS FOR PARTICULAR PURPOSE, ARE LIMITED TO THE WARRANTY PERIOD SET FORTH ABOVE.

Some states do not allow the exclusion of incidental or consequential damages or limitations on how long an implied warranty lasts, so these limitations or exclusions may not apply to you. This warranty gives you specific legal rights and you may also have other rights which vary from state to state.

JVC COMPANY OF AMERICA 1700 Valley Road
 DIVISION OF JVC AMERICAS CORP. Wayne, New Jersey 07470
<http://www.jvc.com>

REFURBISHED PRODUCTS CARRY A SEPARATE WARRANTY, THIS WARRANTY DOES NOT APPLY. FOR DETAILS OF REFURBISHED PRODUCT WARRANTY, PLEASE REFER TO THE REFURBISHED PRODUCT WARRANTY INFORMATION PACKAGED WITH EACH REFURBISHED PRODUCT.

For customer use:

Enter below the Model No. which is located either on the rear, bottom or side of the cabinet. Retain this information for future reference.

Model No. : _____

Serial No. : _____

Purchase data : _____

Name of dealer : _____

TO OUR VALUED CUSTOMER ———

THANK YOU FOR PURCHASING THIS JVC PRODUCT.
WE WANT TO HELP YOU ACHIEVE A PERFECT EXPERIENCE.

**NEED HELP ON HOW TO HOOK UP?
NEED ASSISTANCE ON HOW TO OPERATE?
NEED TO LOCATE A JVC SERVICE CENTER?
LIKE TO PURCHASE ACCESSORIES?**

JVC[®] IS HERE TO HELP!
TOLL FREE: 1(800)252-5722
<http://www.jvc.com>

Remember to retain your Bill of Sale for Warranty Service.

————— **Do not attempt to service the product yourself** —————

Caution

To prevent electrical shock, do not open the cabinet.
There are no user serviceable parts inside.
Please refer to qualified service personnel for repairs.

JVC

